



Chip Ferrite Inductor (MFI Series) Engineering Spec.

■ PRODUCT DETAIL

Electrical Characteristics			Test Instruments
L	μH (Ref. Page 6~9)	TEST FREQ: (Ref. Page 6~9) MHz	•HP4291B RF IMPEDANCE / MATERIAL ANALYZER •HP4338A/B MILLIOHM METER •Agilent 8720ES S-PARAMETER NETWORK ANALYZER •HP6632B SYSTEM DC POWER SUPPLY
Q	(Min) (Ref. Page 6~9)		
SRF	MHz (Min) (Ref. Page 6~9)		
DCR	Ω (Ref. Page 6~9)	TEST LEVEL: 100 mV	
IDC	mA (Ref. Page 6~9)		

■ SHAPES AND DIMENSIONS

Unit: mm

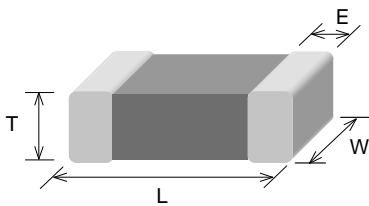

TYPE	1608 (EIA0603)	201209 (EIA 0805)	201212 (EIA 0805)	3216 (EIA 1206)
L	1.60±0.15	2.00±0.20	2.00±0.20	3.20±0.20
W	0.80±0.15	1.25±0.2	1.25±0.20	1.60±0.20
T	0.80±0.15	0.90±0.20	1.25±0.20	1.10±0.20
E	0.30±0.20	0.50±0.30	0.50±0.30	0.50±0.30

The thickness of 2012 specification under 4.7 μH is 0.90mm±0.20mm

■ PART NUMBER CODE

MFI 3216 4R7 K B E
 1 2 3 4 5 6

- 1 Series Name
- 2 Size Code: the first two digitals : length(mm), the last two digitals : width(mm)
- 3 Inductance (R=Decimal Point) Unit: μH
- 4 Tolerance: J= ±5%, K= ±10%, M = ±20%
- 5 Soldering : Green Parts: A— Soldering Lead-Free B— Lead-Free for whole chip
- 6 Packaging: P - Embossed paper tape, 7" reel.
 E - Embossed plastic tape, 7" reel.

■ TAPE AND REEL SPECIFICATIONS
PLASTIC CARRIER

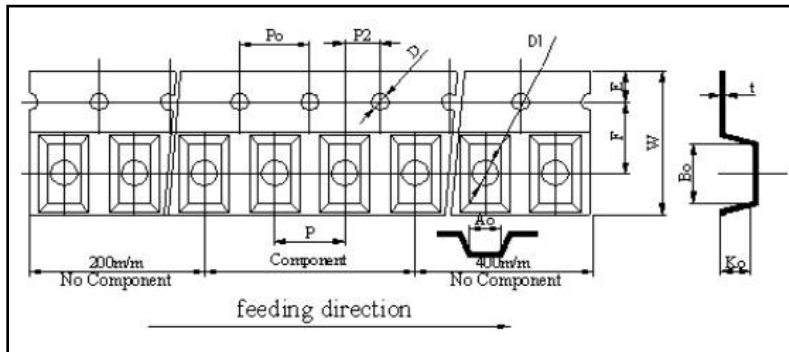

PAPER CARRIER

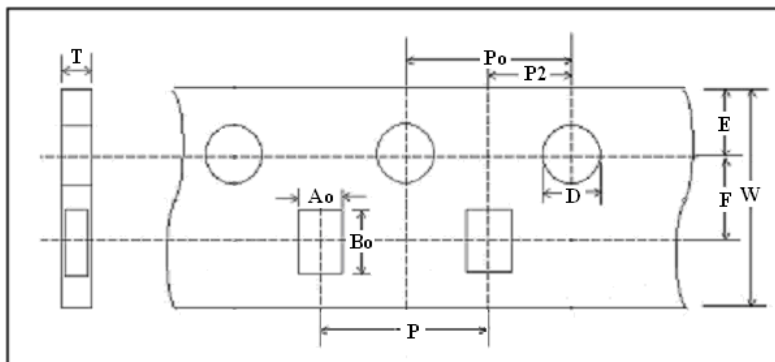

■ TAPING DIMENSIONS

Unit: mm

Size	3216	201212	201209	1608
Symbol	PLASTIC	PLASTIC	PAPER	PAPER
W	7.90~8.30	7.90~8.30	8.00±0.10	8.00±0.10
P	4.00±0.10	4.00±0.10	4.00±0.10	4.00±0.10
E	1.75±0.10	1.75±0.10	1.75±0.10	1.75±0.10
F	3.50±0.05	3.50±0.05	3.50±0.10	3.50±0.10
D	1.55±0.05	1.50±0.05	1.56±0.10	1.56±0.10
D1	0.95~1.20	0.95~1.20	NA	NA
Po	4.00±0.10	4.00±0.10	4.00±0.10	4.00±0.10
Po10	40.0±0.20	40.0±0.20	40.0±0.20	NA
P2	2.00±0.05	2.00±0.05	2.00±0.1	2.00±0.10
Ao	1.85±0.10	1.42±0.10	1.50±0.05	1.05±0.05
Bo	3.43±0.10	2.26±0.10	2.30±0.05	1.85±0.05
Ko(T)	1.22±0.10	1.30±0.10	0.95±0.05	0.95±0.05
t	0.25±0.10	0.23±0.10	NA	NA

■ REEL DIMENSIONS

Unit: mm

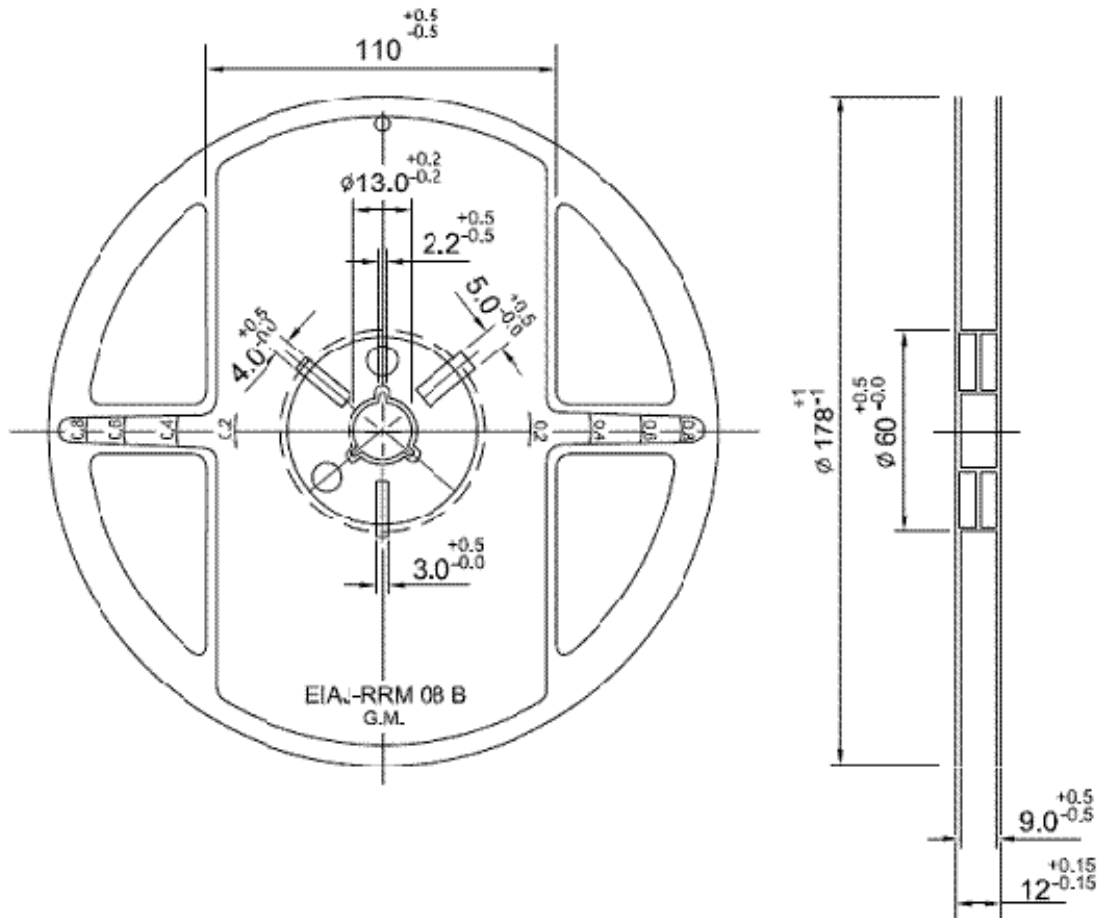

Reel Packaging Quantity					
PART SIZE (EIA SIZE)		1608 (0603)	201209 (0805)	201212 (0805)	3216 (1206)
7" REEL	Qty. (pcs)	4,000	4,000	3,000	3,000

The Contents of a box :

- 3216 (1206): 5 reels / inner box
- 2012 (0805): 5 reels / inner box
- 1608 (0603): 5 reels / inner box

■ RECOMMENDED SOLDERING CONDITIONS

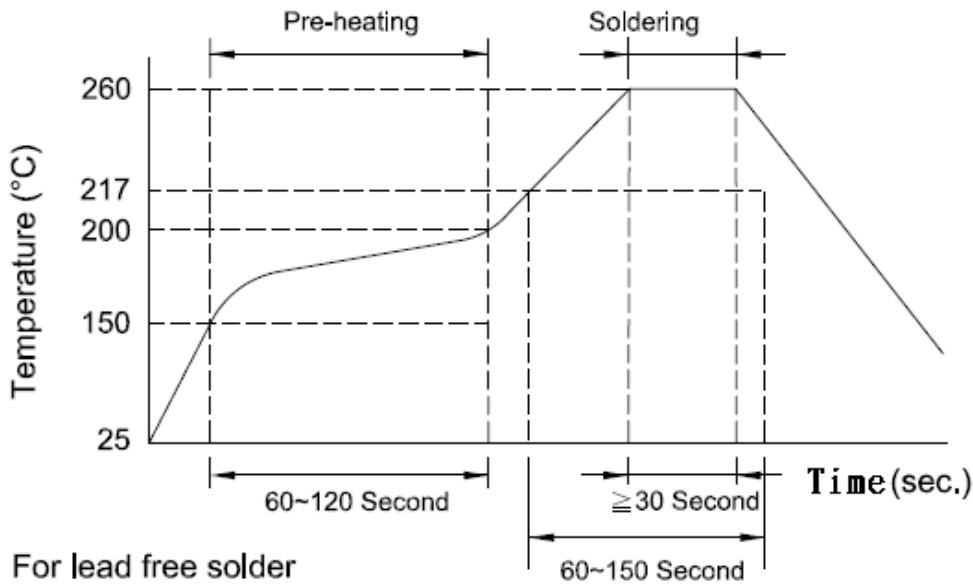

■ LAND PATTERNS FOR REFLOW SOLDERING

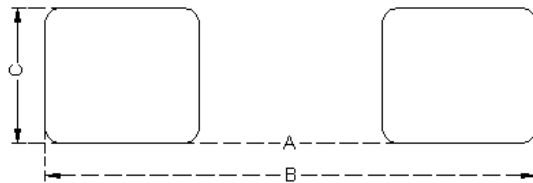

■ SOLDER LAND INFORMATION

Unit: mm (inches)

Size	A	B	C
1608	0.5 ~ 0.7 (0.019 ~ 0.027)	2.1 ~ 3.1 (0.083 ~ 0.122)	0.65 ~ 0.95 (0.026 ~ 0.037)
2012	1.0 ~ 1.2 (0.039 ~ 0.047)	3.0 ~ 4.0 (0.118 ~ 0.157)	0.8 ~ 1.1 (0.031 ~ 0.043)
3216	2.0 ~ 2.4 (0.079 ~ 0.094)	4.2 ~ 5.2 (0.165 ~ 0.204)	1.0 ~ 1.4 (0.039 ~ 0.055)

■ RELIABILITY AND TEST CONDITION

Test item	Test condition	Criteria
Temperature Cycle	a. Temperature : -40 ~ +85°C b. Cycle : 100 cycles c. Dwell time : 30minutes d. Measurement : at ambient temperature 24 hrs after test completion	a. No mechanical damage b. Induction value should be within $\pm 10\%$ of the initial value c. Q vale should be within $\pm 30\%$ of the initial value
Operational Life	a. Temperature : 125°C $\pm 5^\circ\text{C}$ b. Test time : 1000 hrs c. Apply current : full rated current d. Measurement : at ambient temperature 24 hrs after test completion	a. No mechanical damage b. Induction value should be within $\pm 10\%$ of the initial value c. Q vale should be within $\pm 30\%$ of the initial value
Biased Humidity	a. Temperature : 40°C $\pm 2^\circ\text{C}$ b. Humidity : 90 ~ 95 % RH c. Test time : 1000 hrs d. Apply current : full rated current e. Measurement : at ambient temperature 24 hrs after test completion	a. No mechanical damage b. Induction value should be within $\pm 10\%$ of the initial value c. Q vale should be within $\pm 30\%$ of the initial value
Resistance to Solder Heat	a. Solder temperature : 260 $\pm 5^\circ\text{C}$ b. Flux : Rosin c. DIP time : 10 ± 1 sec	a. More than 95 % of terminal electrode should be covered with new solder b. No mechanical damage c. Induction value should be within $\pm 10\%$ of the initial value d. Q vale should be within $\pm 30\%$ of the initial value
Adhesive Test	a. Reflow temperature : 245°C It shall be Soldered on the substrate applying direction parallel to the substrate b. Apply force(F) : 5 N Test time : 10 sec	a. No mechanical damage b. Soldering the products on PCB after the pulling test force > 5 N

Test item	Test condition	Criteria
Steam Aging Test	a. Temperature : 93°C b. Test time : 8 hrs c. Solder temperature : 235 ± 5°C d. Flux : Rosin e. DIP time : 5 ± 1 sec	More than 95 % of terminal electrode should be covered with new solder

■ GENERAL TECHNICAL DATA

Operating temperature range : - 55°C ~ +125°C

Storage Condition : Less than 40°C and 70% RH

Storage Time: 12 months Max.

Soldering method: Reflow or Wave Soldering

■ PART NUMBER AND CHARACTERISTICS TABLE

Part No.	Thickness (mm)	Inductance & Tolerance (μH)	Q (min)	Test Freq. (MHz)	S.R.F (MHz) Min	DCR(Ω) (Max.)	Rated Curren (mA)
MFI1608 Series							
MFI1608 R10KB_	0.8 ± 0.15	0.10 ± 10%	15	25	240	0.50	50
MFI1608 R12KB_	0.8 ± 0.15	0.12 ± 10%	15	25	235	0.50	50
MFI1608 R15KB_	0.8 ± 0.15	0.15 ± 10%	15	25	205	0.60	50
MFI1608 R18KB_	0.8 ± 0.15	0.18 ± 10%	15	25	190	0.60	50
MFI1608 R22KB_	0.8 ± 0.15	0.22 ± 10%	15	25	170	0.80	50
MFI1608 R27KB_	0.8 ± 0.15	0.27 ± 10%	15	25	155	0.80	50
MFI1608 R33KB_	0.8 ± 0.15	0.33 ± 10%	15	25	140	0.80	35
MFI1608 R39KB_	0.8 ± 0.15	0.39 ± 10%	15	25	125	1.00	35
MFI1608 R47KB_	0.8 ± 0.15	0.47 ± 10%	15	25	120	1.00	35
MFI1608 R56KB_	0.8 ± 0.15	0.56 ± 10%	15	25	110	1.55	35
MFI1608 R68KB_	0.8 ± 0.15	0.68 ± 10%	15	25	100	1.70	35
MFI1608 R82KB_	0.8 ± 0.15	0.82 ± 10%	15	25	95	2.10	35
MFI1608 1R0KB_	0.8 ± 0.15	1.0 ± 10%	35	10	85	0.60	25
Part No.	Thickness (mm)	Inductance & Tolerance (μH)	Q (min)	Test Freq. (MHz)	S.R.F (MHz) Min	DCR(Ω) (Max.)	Rated Curren (mA)
MFI1608 Series							
MFI1608 1R2KB_	0.8 ± 0.15	1.2 ± 10%	35	10	70	0.80	25

MFI1608 1R5KB_	0.8 ± 0.15	1.5 ± 10%	35	10	65	0.80	25
MFI1608 1R8KB_	0.8 ± 0.15	1.8 ± 10%	35	10	60	0.80	25
MFI1608 2R2KB_	0.8 ± 0.15	2.2 ± 10%	35	10	55	1.00	15
MFI1608 2R7KB_	0.8 ± 0.15	2.7 ± 10%	35	10	50	1.20	15
MFI1608 3R3KB_	0.8 ± 0.15	3.3 ± 10%	35	10	45	1.40	15
MFI1608 3R9KB_	0.8 ± 0.15	3.9 ± 10%	40	10	42	1.60	15
MFI1608 4R7KB_	0.8 ± 0.15	4.7 ± 10%	40	10	40	1.80	15
MFI1608 10RKB_	0.8 ± 0.15	10.0 ± 10%	30	2	17	1.85	3
MFI2012 Series							
MFI2012 R10KB_	0.9 ± 0.2	0.10 ± 10%	20	25	255	0.30	250
MFI2012 R12KB_	0.9 ± 0.2	0.12 ± 10%	20	25	250	0.30	250
MFI2012 R15KB_	0.9 ± 0.2	0.15 ± 10%	20	25	230	0.40	250
MFI2012 R18KB_	0.9 ± 0.2	0.18 ± 10%	20	25	210	0.40	250
MFI2012 R22KB_	0.9 ± 0.2	0.22 ± 10%	20	25	195	0.50	250
MFI2012 R27KB_	0.9 ± 0.2	0.27 ± 10%	20	25	170	0.50	250
MFI2012 R33KB_	0.9 ± 0.2	0.33 ± 10%	20	25	165	0.50	250
MFI2012 R39KB_	0.9 ± 0.2	0.39 ± 10%	25	25	155	0.60	200
MFI2012 R47KB_	0.9 ± 0.2	0.47 ± 10%	25	25	140	0.60	200
MFI2012 R56KB_	0.9 ± 0.2	0.56 ± 10%	25	25	130	0.70	150
MFI2012 R68KB_	0.9 ± 0.2	0.68 ± 10%	25	25	120	0.80	150
MFI2012 R82KB_	0.9 ± 0.2	0.82 ± 10%	25	25	115	1.00	150
MFI2012 1R0KB_	0.9 ± 0.2	1.0 ± 10%	45	10	85	0.40	50
MFI2012 1R2KB_	0.9 ± 0.2	1.2 ± 10%	45	10	75	0.50	50
MFI2012 1R5KB_	0.9 ± 0.2	1.5 ± 10%	45	10	65	0.50	50
MFI2012 1R8KB_	0.9 ± 0.2	1.8 ± 10%	45	10	60	0.60	50
MFI2012 2R2KB_	0.9 ± 0.2	2.2 ± 10%	45	10	55	0.60	30
MFI2012 2R7KB_	0.9 ± 0.2	2.7 ± 10%	45	10	50	0.70	30
MFI2012 3R3KB_	0.9 ± 0.2	3.3 ± 10%	45	10	45	0.80	30
MFI2012 3R9KB_	0.9 ± 0.2	3.9 ± 10%	45	10	44	0.90	30
MFI2012 4R7KB_	0.9 ± 0.2	4.7 ± 10%	45	10	41	0.90	30
MFI2012 5R6KB_	1.25 ± 0.2	5.6 ± 10%	50	4	37	0.90	15
Part No.	Thickness (mm)	Inductance & Tolerance (μH)	Q (min)	Test Freq. (MHz)	S.R.F (MHz) Min	DCR(Ω) (Max.)	Rated Curren (mA)
MFI2012 Series							
MFI2012 6R8KB_	1.25 ± 0.2	6.8 ± 10%	50	4	34	1.00	15
MFI2012 8R2KB_	1.25 ± 0.2	8.2 ± 10%	50	4	30	1.10	15
MFI2012 10RKB_	1.25 ± 0.2	10.0 ± 10%	50	2	28	1.00	15
MFI2012 12RKB_	1.25 ± 0.2	12.0 ± 10%	50	2	26	1.10	15
MFI2012 15RKB_	1.25 ± 0.2	15.0 ± 10%	35	1	22	0.80	5

MFI2012 18RKB_	1.25 ± 0.2	18.0 ± 10%	35	1	21	0.90	5
MFI2012 22RKB_	1.25 ± 0.2	22.0 ± 10%	35	1	19	1.10	5
MFI3216 Series							
MFI3216 R10KB_	1.1 ± 0.2	0.10 ± 10%	20	25	270	0.25	250
MFI3216 R12KB_	1.1 ± 0.2	0.12 ± 10%	20	25	250	0.3	250
MFI3216 R15KB_	1.1 ± 0.2	0.15 ± 10%	20	25	200	0.3	250
MFI3216 R18KB_	1.1 ± 0.2	0.18 ± 10%	20	25	185	0.4	250
MFI3216 R22KB_	1.1 ± 0.2	0.22 ± 10%	20	25	170	0.4	250
MFI3216 R27KB_	1.1 ± 0.2	0.27 ± 10%	20	25	150	0.5	250
MFI3216 R33KB_	1.1 ± 0.2	0.33 ± 10%	20	25	145	0.5	250
MFI3216 R39KB_	1.1 ± 0.2	0.39 ± 10%	25	25	135	0.5	200
MFI3216 R47KB_	1.1 ± 0.2	0.47 ± 10%	25	25	125	0.6	200
MFI3216 R56KB_	1.1 ± 0.2	0.56 ± 10%	25	25	115	0.7	150
MFI3216 R68KB_	1.1 ± 0.2	0.68 ± 10%	25	25	105	0.8	150
MFI3216 R82KB_	1.1 ± 0.2	0.82 ± 10%	25	25	100	0.9	150
MFI3216 1R0KB_	1.1 ± 0.2	1.0 ± 10%	45	10	87	0.4	100
MFI3216 1R2KB_	1.1 ± 0.2	1.2 ± 10%	45	10	75	0.5	100
MFI3216 1R5KB_	1.1 ± 0.2	1.5 ± 10%	45	10	69	0.5	50
MFI3216 1R8KB_	1.1 ± 0.2	1.8 ± 10%	45	10	64	0.5	50
MFI3216 2R2KB_	1.1 ± 0.2	2.2 ± 10%	45	10	58	0.6	50
MFI3216 2R7KB_	1.1 ± 0.2	2.7 ± 10%	45	10	52	0.6	50
MFI3216 3R3KB_	1.1 ± 0.2	3.3 ± 10%	45	10	48	0.7	50
MFI3216 3R9KB_	1.1 ± 0.2	3.9 ± 10%	45	10	44	0.8	50
MFI3216 4R7KB_	1.1 ± 0.2	4.7 ± 10%	45	10	41	0.9	50
MFI3216 5R6KB_	1.1 ± 0.2	5.6 ± 10%	50	4	32	0.8	25
MFI3216 6R8KB_	1.1 ± 0.2	6.8 ± 10%	50	4	29	0.9	25
MFI3216 8R2KB_	1.1 ± 0.2	8.2 ± 10%	50	4	26	1	25
Part No.	Thickness (mm)	Inductance & Tolerance (µH)	Q (min)	Test Freq. (MHz)	S.R.F (MHz) Min	DCR(Ω) (Max.)	Rated Current (mA)
MFI3216 Series							
MFI3216 10RKB_	1.1 ± 0.2	10.0 ± 10%	50	2	26	0.6	25
MFI3216 12RKB_	1.1 ± 0.2	12.0 ± 10%	50	2	26	0.6	15
MFI3216 15RKB_	1.1 ± 0.2	15.0 ± 10%	50	1	22	0.7	5
MFI3216 18RKB_	1.1 ± 0.2	18.0 ± 10%	50	1	21	0.7	5
MFI3216 22RKB_	1.1 ± 0.2	22.0 ± 10%	50	1	19	0.9	5

** For special part number which is not shown in above table, please refer to the appendix.